

Living inspiration

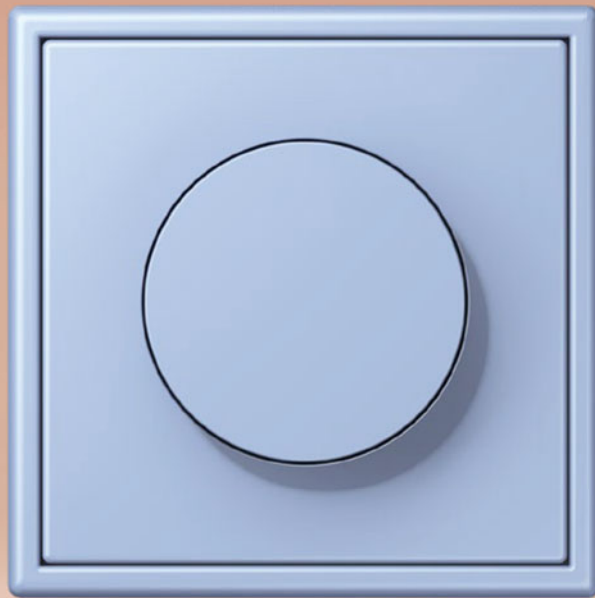

EN



# Living inspiration

This insight into the JUNG product world gives you an overview of the timeless designs, materials, colours and surfaces of our switch ranges as well as a selection of the many different solutions for intelligent control of the home.

Get inspired!

## JUNG

Progress as tradition	4
-----------------------	---

## DESIGN

LS range	8
A range	24
CD range	38

## SOLUTIONS

Lighting	44
Shading	48
Temperature	50
Orientation light	52
Smart Radio DAB+	54
Connection systems	56
SCHUKO® socket with USB	58
International sockets	60
Door communication	62
Plug & Light	64

## SMART HOME

System overview	66
JUNG HOME	68
eNet SMART HOME	76
KNX	82
Central control	84
Intelligent Voice Control	88
Control panels	90
KNX room controller	94
KNX control in the switch design	96
Wireless operation	102

## OTHER

GRAPHIC TOOL	104
Overview of switch ranges	106
Multiple sustainability	112
Cradle to Cradle certification	113
JUNG Social Media	114



Business partner Ernst Paris

Company founder Albrecht Jung

## Progress as tradition

JUNG stands for timeless design and future-oriented solutions worldwide. Innovation, passion and precision have been guiding our product developments for more than 110 years. Light, shading, room climate, energy, security, door communication and multimedia – our systems provide the appropriate solution for every requirement.

With 1,700 employees we are present on 5 continents in 90 countries with 21 subsidiaries and independent sales and partner organizations. Whether private, commercial or hotel construction: Architects, planners and Craft producers worldwide place their trust in the innovative solutions from JUNG. Our building technology can be found in the Reichstag in Berlin as well as in the Hermitage in St. Petersburg or the Shangri-La Hotel in Singapore.

We consciously combine this internationality with close ties to the headquarters of our family business in Schalksmühle. We develop and manufacture components for classic electrical installations as well as intelligent systems for building technology. Flow production, small series or manufacture: Our modern production methods meet the highest requirements.

### WE ARE JUNG:

1912

Medium-sized third generation family company



“Made in Germany” for more than 110 years



Around 1,700 employees



21 subsidiaries and over 80 agencies worldwide

# Products “Made in Germany” – made with precision

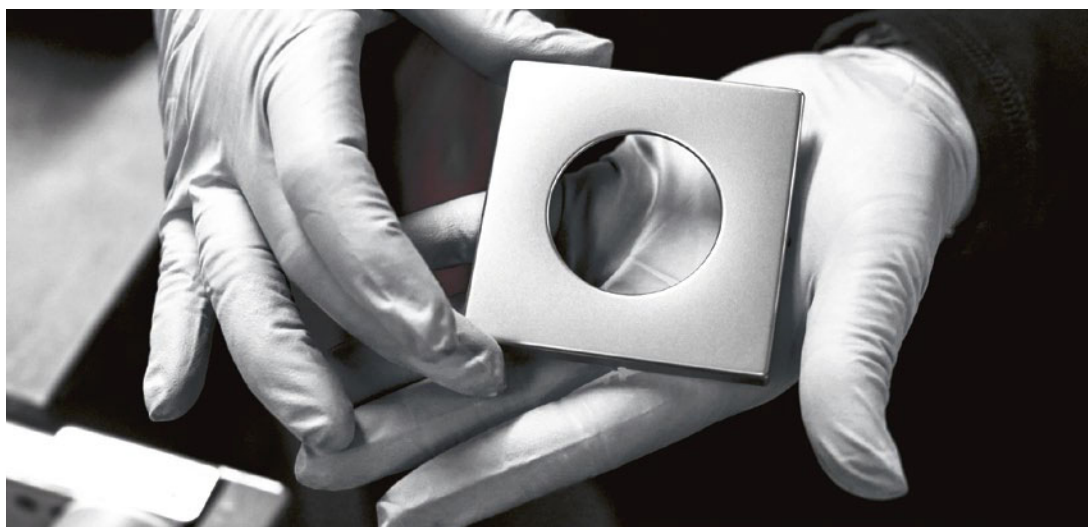

Our products are manufactured at the two company sites in Schalksmühle and Lünen. With deep roots in the region and a constant employer for many decades, customers throughout the world rely on the continuing high quality. At the same time, we are aware of our high responsibility for sustainable and energy-efficient production. JUNG has proven

its specialist know-how in metalworking for decades. We provide our switch designs in genuine metal. Matt finished or lacquered aluminium, stainless steel blasted with glass beads, brushed brass, chrome-plated metal or with almost 24 carat gold plating – JUNG produces precision switches down to the last detail every day.



# LS range – Time for genuine classics

There are things that never go out of fashion: genuine classics like the designs of the LS range. With their square basic shape, straight lines and clear design language, they fit timelessly and elegantly into any ambience. The selection of high quality materials and surfaces provides all possibilities to realise personal furnishing styles. From surface-mounted installation to individual lacquering to flush-mounted wall and furniture installation.





Dual combination of push-button with SCHUKO® socket with USB A + C in the range LS 990 in matt snow white



Switch in the LS 990 range in stainless steel

# LS 990

## SWITCH / SOCKET COMBINATION



in matt snow white

## ROTARY DIMMER



in anthracite

## MOTION DETECTOR



in aluminium

The LS 990 flat switch is the classic among light switches. A slim frame and a maximum operating surface characterise the reduced design. In timeless colours, elegant matt lacquering, made of stainless steel, aluminium, brass, chrome-plated or with exclusive gold

plating – with its timeless aesthetics, the LS 990 has been impressive for more than 50 years. In addition to its purist design, it is mainly its wide range of functions that make the range the favourite whenever high-quality furnishing concepts are required.

# LS 990 in Les Couleurs® Le Corbusier

## ROTARY DIMMER



in 32031 céruleén vif

## 2-GANG SWITCH



in 32011 gris 31

## F 50 KNX PUSH-BUTTON



in 32033 céruleén clair

## SCHUKO® SOCKET



in 32013 gris clair 31

JUNG sets accents with LS 990 in Les Couleurs® Le Corbusier. What is so special about this colour system: Le Corbusier has perfectly coordinated the 63 colours and thus made them harmoniously combinable through the entire range. Impressed by the extraordinary appearance, JUNG exclusively provides light

switches in the impressive colours worldwide. The matt surface results from hand lacquering in a special process. Inscriptions using the Graphic Tool are possible. Thanks to the JUNG modular system, all covers can be combined with the LS range inserts.



LS 990 in Les Couleurs® Le Corbusier  
32033 céruléen clair





KNX push-button F 40  
in the range LS ZERO in matt graphite black

# LS ZERO



LS ZERO is the flush-mounted new interpretation of the LS 990 classic switch. Switches, door intercoms and connections for building technology can be integrated almost flowing into the interior – ideal for installation in furniture, brickwork or drywall. With over 200 different inserts, the range provides all options

for modern building control. Elegant in white, precious metal colours or in the 63 colours of Les Couleurs® Le Corbusier. Alternatively, LS ZERO is also available in a version with an installation height of 3 millimetres for flat mounting on wallpaper.

# LS CUBE

## SWITCH / SOCKET COMBINATION



in stainless steel look

## SWITCHES / PUSH-BUTTONS



in white

## F 40 PUSH-BUTTON, 4-GANG



in aluminium look

With LS CUBE, JUNG provides a modern surface mounted variant of the LS 990 design classic. LS CUBE is the optimal solution if there is no possibility of flush mounting or if surface-mounted installations are to be used as a deliberate stylistic device. The striking design of the range is ideal for open spaces

with loft character. LS CUBE particularly stands out aesthetically on exposed concrete and natural stone. But the range also looks good on rustic wooden beams. LS CUBE is available in numerous colour and material variants; the functional diversity of the range also leaves nothing to be desired.





# LS1912<sup>®</sup>

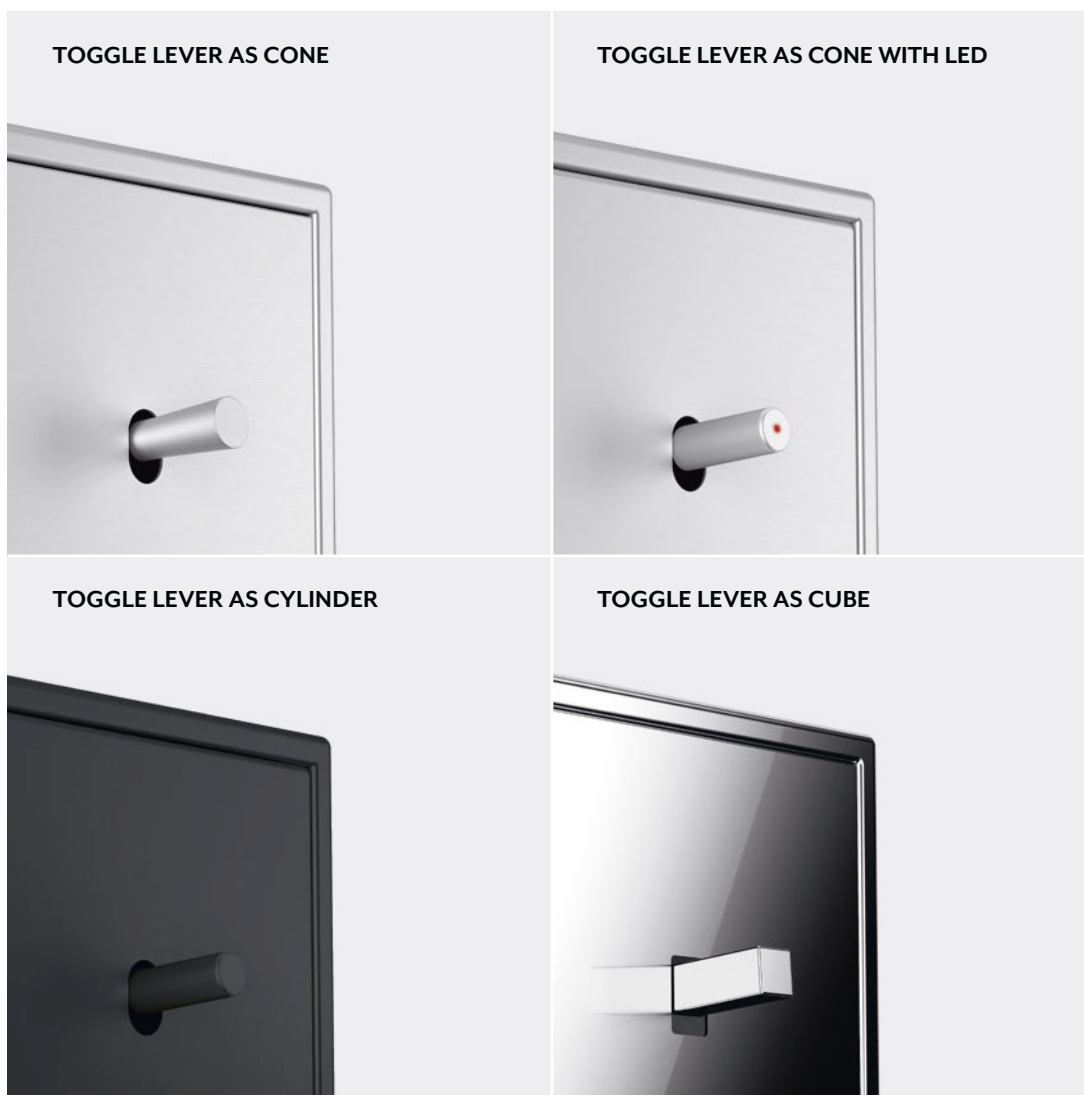

As a homage to the JUNG switches of the early years, the toggle switch LS 1912 brings the mechanics of switching to life in a new way. The switch mechanism is designed so that the cover closes flush with the frame. Only the toggle lever in the shape of a cylinder, cone or cube extends from the unit as a style element. LS 1912 with matt colours is particularly suitable for a

timeless and above all reduced interior design. In the version with indicator lamp, an LED in the toggle lever indicates the switching status or provides orientation. The multi push-button insert extends LS 1912 by an additional toggle switch position. The LS 1912 range can be seamlessly integrated into the JUNG systems for smart building control.



Toggle switch 2-gang  
in Les Couleurs® Le Corbusier vert olive vif

# LS 1912 in Les Couleurs® Le Corbusier

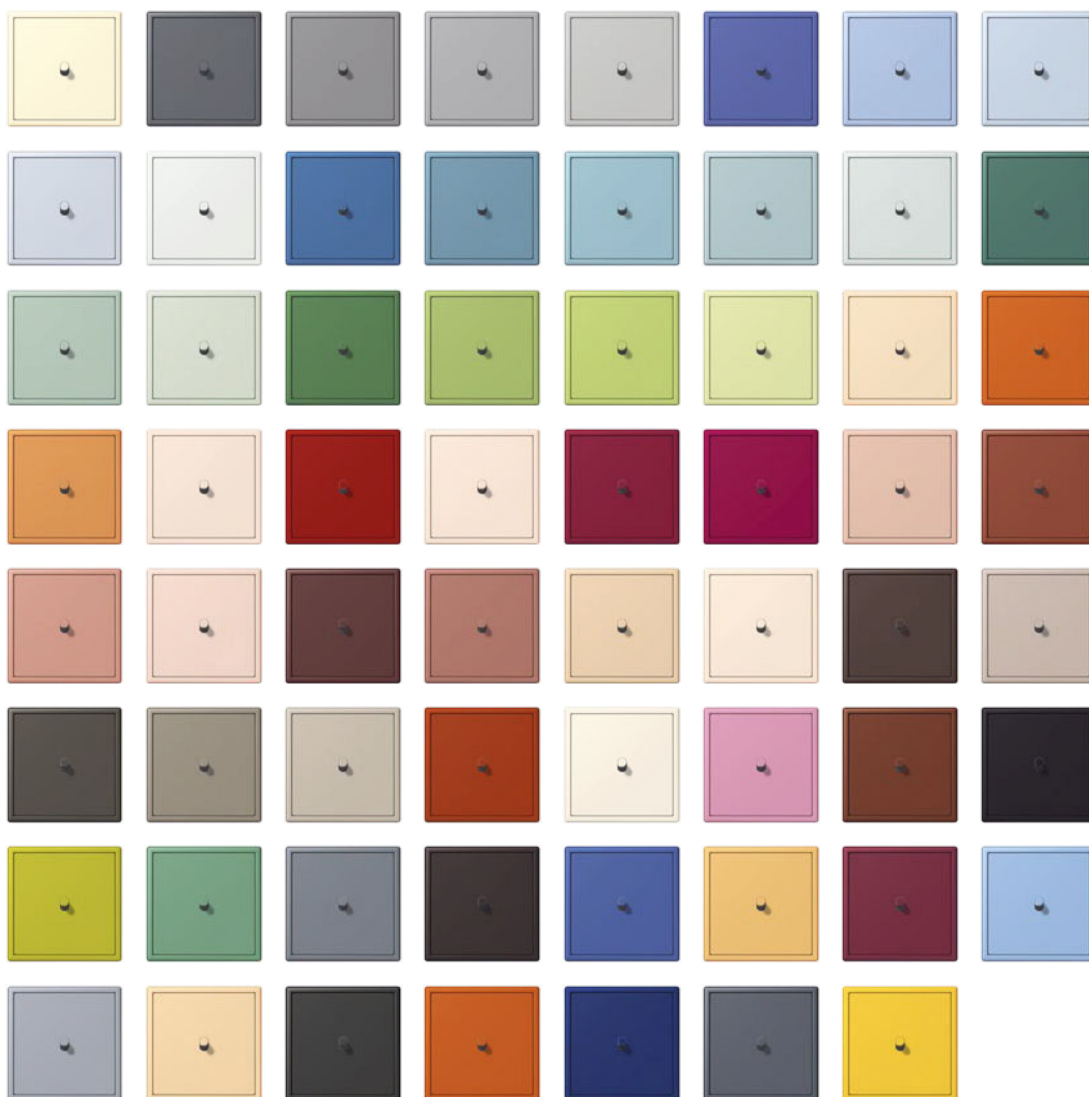

Puristic design, varied colours: The JUNG toggle switch LS 1912 in the cylinder version is now also available in the 63 colours of Les Couleurs® Le Corbusier. That opens up a wide range of design possibilities. In this way, a coherent overall picture arises in the room, where the electrical installation

with LS 1912 inserts itself visually into the colour scheme and the style of the interior. The hand lacquered toggle switches are produced to order. The delivery time is approx. ten weeks after receipt of order. Classic form, versatile technology: LS 1912 covers many functions as push-button, switch or now as multi push-button.



## LS PLUS

The expressive LS PLUS range sets standards in elegance and aesthetics. The conspicuously wide frames in real glass in the colours white, black and soft white, together with the large-surface rockers, create a look that is surprisingly different.



## LS DESIGN

The frames of the LS DESIGN range made of high-quality metal or plastic appear extraordinarily light. A discreet shadow gap on the rear side makes the difference. Light switches, sockets and push-buttons appear to float on the wall. The JUNG modular principle provides numerous possibilities to individually combine the components of the LS DESIGN range.



## A range – Creativity demonstrates diversity

Set accents in the room: The modern A range provides a wealth of interesting ideas in form, colour and material that fit into any interior.







SCHUKO® socket with USB type C and JUNG Quick Charge® function in the range A 550 in black

# A 550

## ROTARY DIMMER

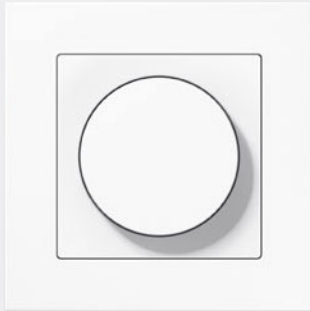

in white

## SWITCHES/PUSH BUTTONS



in matt graphite black

## SCHUKO® SOCKET



in aluminium look

## F 40 PUSH-BUTTON, 4-GANG



in matt anthracite

Concentrated on the essentials, A 550 is impressive due to a minimalist and striking design. The linear, uncompromising look of the range stands for a clear design language and perfectly complements modern furnishing styles.

In aluminium look, anthracite, mocha, champagne, black and white, and particularly in the elegant matt graphite black and matt snow white lacquers, the A 550 range sets accents.

# A FLOW

**PUSH-BUTTON, 2-GANG**

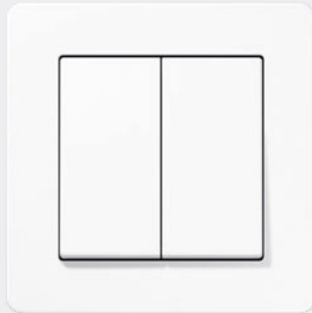

in white

**JUNG HOME PUSH-BUTTON, 1-GANG**



in black

**F 40 COMPACT ROOM CONTROLLER**



in aluminium look

**F 50 PUSH-BUTTON, 4-GANG**



in matt anthracite

Young, modern and adaptable: A FLOW remains stylish even if tastes change. With its light, harmonious design, A FLOW blends confidently into different interior styles.

The range is available in aluminium look, anthracite, mocha, champagne, black and white, and in the matt graphite black and matt snow white colours.



KNX F 40 push-button  
in the range A FLOW in matt graphite black



Switch in the range A CREATION  
with glass frame in white

# A CREATION

**F 40 PUSH-BUTTON, 2-GANG**



with frames in duroplastic in mocha

**SWITCHES / PUSH-BUTTONS**



with glass frame in champagne

**F 50 PUSH-BUTTON, 4-GANG**

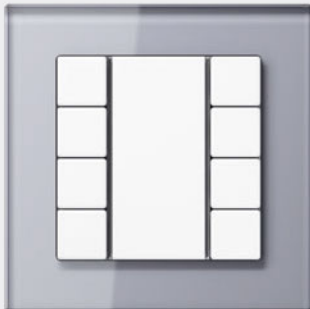

with glass frame in white

**SCHUKO® SOCKET WITH USB CHARGER**



with frames in duroplastic in white

A CREATION is impressive thanks to its expressive design and wide choice of materials. In addition to coloured plastic frames made of duroplastic and breakproof thermoplastic,

A CREATION is also available with frames made of real glass. Due to its wide range of functions, the range covers all areas of modern electrical installation effortlessly.

# A VIVA

**JUNG HOME PUSH-BUTTON, 1-GANG**



with glass frame in black

**ROOM THERMOSTAT**



with glass frame in crystal grey

**PUSH-BUTTON, 2-GANG**



with glass frame in champagne

**SCHUKO® SOCKET WITH USB CHARGER**



with glass frame in emerald green

A VIVA extends the A range portfolio with satin-finished glass frames. The combination of rounded edges and the satin-finished surface makes the glass look soft and breaks up the hardness of

the glass material. All covers for the A range fit on A VIVA. In particular, covers in matt colours underscore the elegant effect of A VIVA.



A VIVA with glass frame in night blue



ACUBE push-button, 1-gang,  
in black

# A CUBE

**PUSH-BUTTON, 1-GANG**



in white

**SCHUKO® SOCKET**



in aluminium look

**KNX F 40 PUSH-BUTTON, 4-GANG**



in matt snow white

**KNX F 50 PUSH-BUTTON, 3-GANG**



in matt graphite black

A CUBE is available in the six colours of A 550 and in 1-gang to 3-gang versions. Multiple combinations can be mounted both vertically and horizontally. The surface-mounted version covers all uses that do not require a deep wall

box. Accessories such as strain relief, cable and pipe inlets ensure easy mounting. With light switches, sockets and multimedia inserts, A CUBE offers a large range of functions.

# AS 500

**SWITCH / SOCKET COMBINATION**



in white

**ROTARY DIMMER**

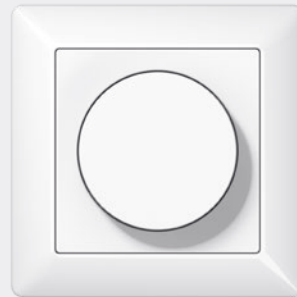

in white

**KNX F 40 PUSH-BUTTON 3-GANG**



in white

In addition to the harmonious lines of the AS 500 in ivory and white, the diffraction of the rocker surface creates a visual accent. The application spectrum includes all techni-

cal possibilities of advanced electrical installation. The protection level IP 44 is ensured with sealing gasket. AS 500 made of breakproof thermoplastic is also available.



Switch in the range AS 500 in white

## CD ranges – Elegance with no rough edges

Discrete colouring and an organic form define the design of the CD range. A visual special feature is the angling of the rocker surface.







## CD PLUS

Showing its colours is not difficult here. CD PLUS leaves almost nothing to be desired with its wide range of colours. With five frame sizes (1 to 5-gang) in three colours and two different applications each in eleven colours, numerous combinations are possible, giving each room its own unique switch colour concept.



## CD 500

With CD 500, form, colour and function form a perfect unit that can be easily integrated into any living space. Six different subtle colours in plastic and two anodised colours in aluminium provide a great variety. In addition, the range has a visual peculiarity due to the angled rocker surface, which makes the switch a special accessory.





## Living comfortably at home

Switches should not only look good, they also have to perform quite a lot. JUNG manages to bridge the gap between sophisticated design and advanced technology in an exemplary manner.

# Lighting control

Show your home in its true light and operate or dim the lighting according to your needs: manually, or automatically to save energy.



## LED UNIVERSAL TOUCH DIMMER

One for all: The LED Universal touch dimmer dims and switches all common lamps safely and conveniently. That is fit-for-the-future dimming convenience.



## LED UNIVERSAL ROTARY DIMMER

The LED Universal rotary dimmer switches and dims all common lamps – reliably and in next to no time.



## LED UNIVERSAL 2-GANG DIMMER

Switch and dim two luminaires independently from each other by pressing a button: Individual switch-on values can be saved separately for each LED lamp or lamp group.



## MOTION DETECTOR

Light when needed: The light is only switched on if someone is in the detection range of the motion detector – and afterwards reliably switched off again. That saves energy.





# Illuminate flexibly

Intuitively with a rotary dimmer, push-button or without any cables: control your lighting manually as usual. A large selection enables the control of various lighting solutions from different suppliers in the JUNG design.

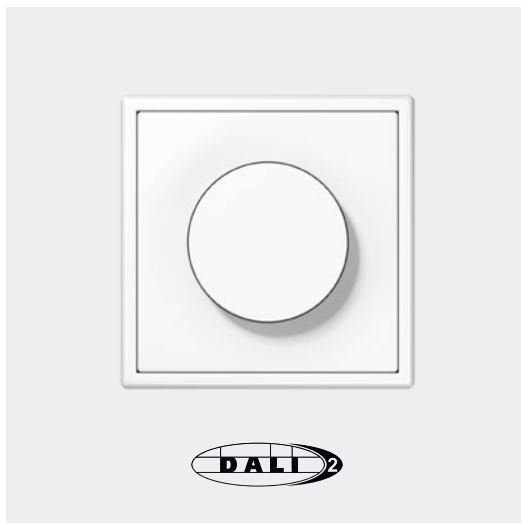

## DALI 2

For the regulation of luminaires with DALI-2 interface, JUNG offers button and rotary control devices.

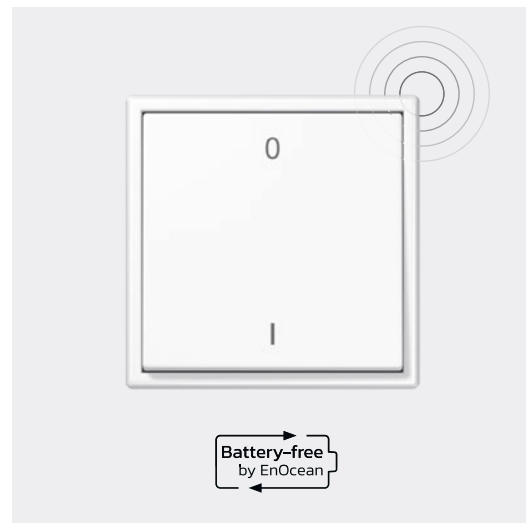

## ENOCEAN

The JUNG radio transmitters with EnOcean technology do not need a cable or batteries.



## BLUETOOTH® LOW ENERGY

Radio transmitters with Bluetooth® Low Energy can be integrated into the digital lighting control from Casambi.

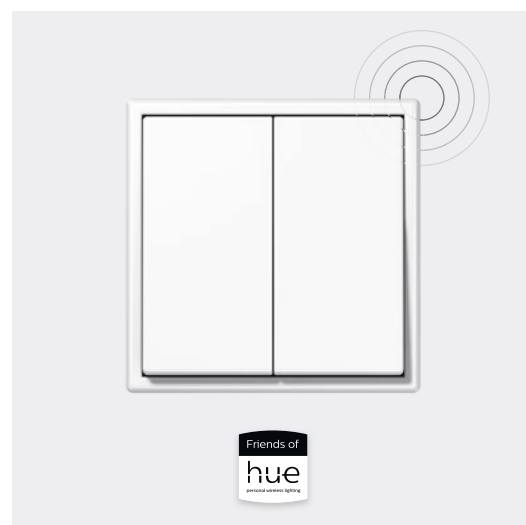

## FRIENDS OF HUE

With these JUNG radio transmitters, the Philips Hue luminaires can be easily controlled.

# Shading control

With JUNG, you are opting for more comfort within your own four walls. To control your shutters, awnings and blinds, JUNG offers you the appropriate solution.



## CONVENTIONAL BLIND PUSH-BUTTON

With a blind switch you can raise and lower the shading reliably and easily. Available in all JUNG design ranges and also as a single switch.



## STANDARD CENTRE PLATE

Use the intelligent push-button to control light or shade. The push-button can be actuated at the top, bottom and also full surface. The cover is available with or without symbols.



## TIMER SWITCH WITH DISPLAY

The timer switch with display is suitable for the control of light and shading. The high-quality, real glass surface has an illuminated display and six sensor buttons for operation.



Blinds push-button / SCHUKO® socket  
in the range A FLOW in matt anthracite



LS 990  
room thermostat  
in stainless steel

# Control temperature

The ideal room temperature depends a great deal on individual perception. An ideal temperature control should therefore above all be flexible. Regulation of the heating for an individual room leads to more efficient use of the heating energy, better adaptation to the individual needs and thus to greater convenience.

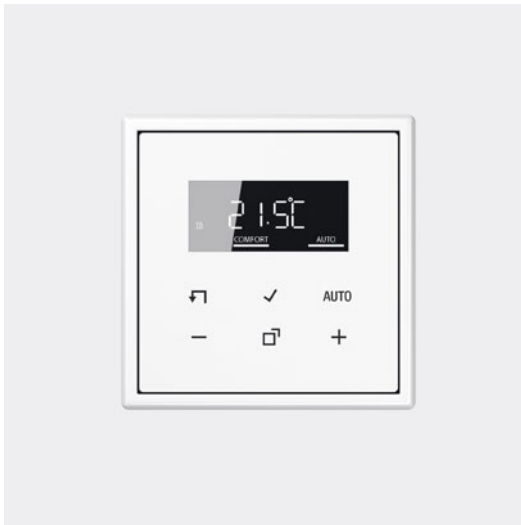

## ROOM THERMOSTAT DISPLAY

The room thermostat display controls underfloor heating systems and radiators, and allows room cooling in combination with a heat pump system.

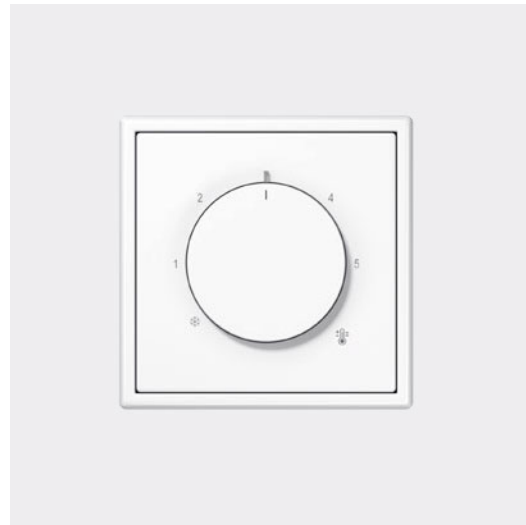

## ROOM THERMOSTAT

The four JUNG room thermostats in the same design as JUNG rotary dimmers offer heating and cooling, ECO mode and temperature drop detection. They also have an LED display and silent switching.

# Safe orientation

With the LED technology, there is an orientation system that is easy to read even in the dark, sets clear signals and effectively shows the way.

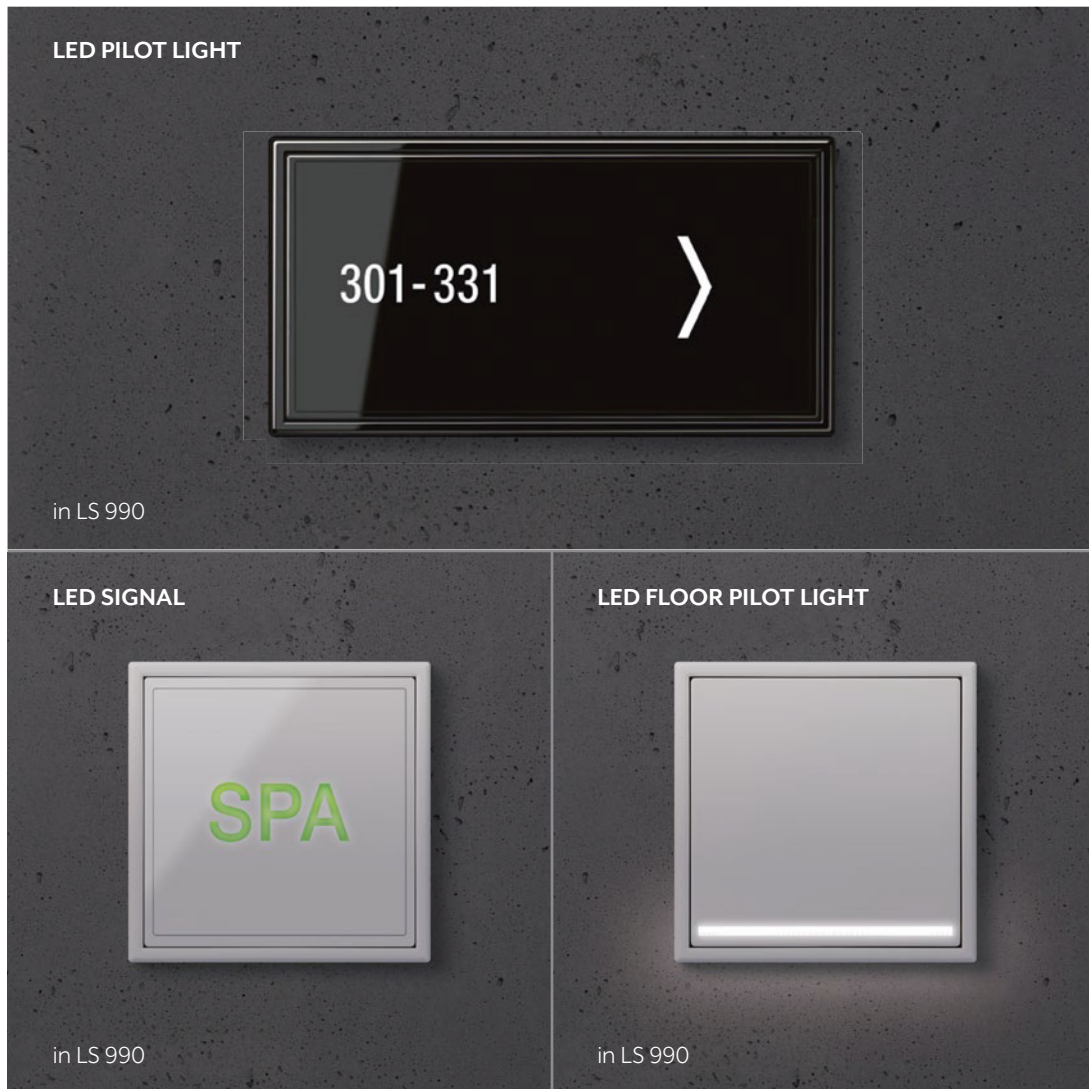

JUNG offers various solutions for safe orientation: LED warning signs and pilot lights can be individually designed. With the LED orientation light, the LED light is installed flush into the design cover, the neutral white LED shines downwards in a defined light beam. Thanks to

the brightness sensor, it only illuminates when the environmental light falls below a specified threshold value. The SCHUKO® sockets with orientation light also ensure safe, non-glare orientation in the dark.



SCHUKO® socket with integrated LED floor pilot light and brightness sensor in the range LS 990



Smart Radio DAB+ Bluetooth® mono set  
in the range LS 990 in chrome

# Smart Radio DAB+



The Smart Radio DAB+ receives programmes via FM and DAB+. It stores up to eight stations per reception mode. Operation is simple. In addition, the Bluetooth® version allows streaming of music. The wall (mounting) radio is

optionally available as mono or stereo version. With its real glass front, the Smart Radio DAB+ is also an optical highlight, available in the various frames in the JUNG design.

# Perfect connection

Tablet, smartphone or television have become an integral part of our lives. The JUNG components provide intelligent solutions and always the right connection for these.



## MODULAR JACK SOCKET, cat. 3

Reliable network connections in all parts of the building and always the correct connection with the JUNG network boxes for 6 and 8-pin plugs.

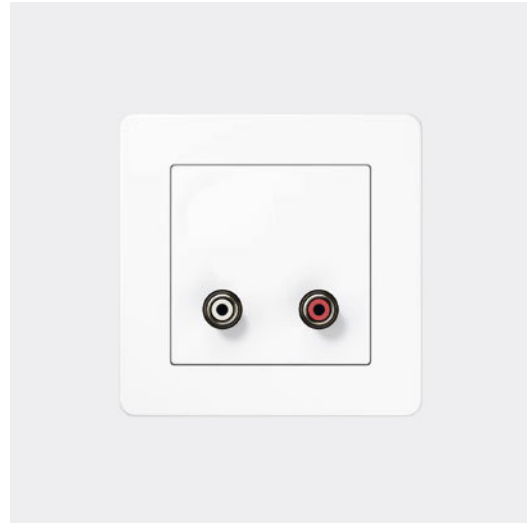

## CINCH AUDIO (RCA)

Versatile possibilities to enjoy HiFi: this wall box has space for two RCA plugs.



## MULTIMEDIA TERMINALS

Home cinema, game console and Full HD screen: To avoid cable clutter, there is the multimedia connection system for analogue, digital and mobile end devices.





SCHUKO® socket with USB A + C  
in the range A FLOW in white

# Flexible all-rounder

## SCHUKO® SOCKET WITH USB-A+C



in LS 990 in stainless steel

## SCHUKO® SOCKET USB-C



in LS 990 Les Couleurs® Le Corbusier  
32100 rouge carmin

## USB CHARGER WITH USB-A+C



in LS 990 in white

## USB CHARGER USB PD 60 WITH USB-C



in LS 990 in black

The JUNG SCHUKO® sockets with USB ports quickly recharge a smartphone, for example, and the socket remains free in the process. The versions with JUNG Quick Charge® have either a USB-A or USB-C port and are impres-

sive with a charging capacity up to 18 watt. USB chargers with up to 60 watt support numerous manufacturer standards for fast charging.

JUNG SCHUKO® sockets with USB port are tested and certified by VDE.





# International socket options

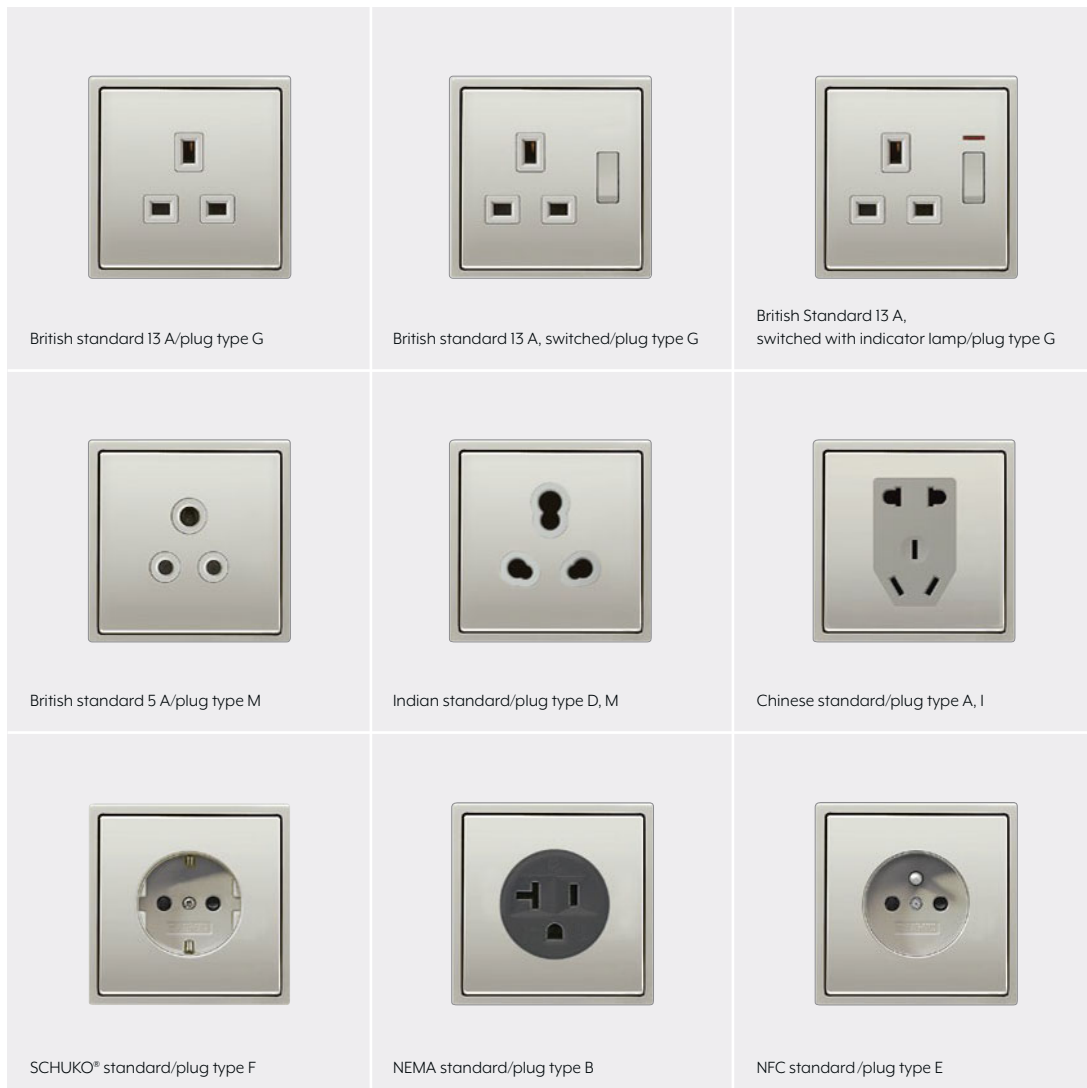

Best worldwide connections: The JUNG modular system provides numerous international socket types according to country-specific standards. The international sockets can be implemented in almost all JUNG design ranges and can also be combined in multiple frames.

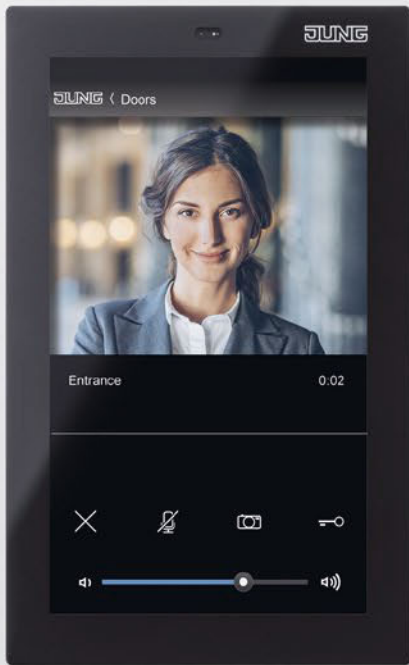

# JUNG door communication

## VIDEO INDOOR STATION



in A FLOW in matt anthracite

## STANDARD AUDIO INDOOR STATION



in A CREATION with glass frame

## AUDIO INDOOR STATION



in LS 990 in aluminium

Door communication with high standards: the JUNG video and audio indoor stations in switch design are impressive in their functionality and appearance. Not only do they have a particularly large selection of designs, they are also perfectly compatible with Siedle door

stations thanks to the use of Siedle system technology. The advantages: easy operation and a large variety of possibilities. The JUNG indoor stations fit in harmoniously with the rest of the electrical installation in the overall design.



# Plug & Light

Dimmable LED light in the matching switch design. Plug & Light gives you great freedom in lighting design – fast and simple to install thanks to the innovative light socket.

## LED SPOTLIGHT



in LS 990 in aluminium

## LED SPOTLIGHT

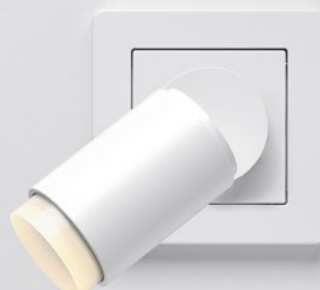

in A FLOW in white

## LED WALL LUMINAIRE



in A CREATION in aluminium look

## LED WALL LUMINAIRE



in A 550 in black

Plug & Light means you can have exactly the right light for every situation. The modern LED system consists of a light socket where the various LED light attachments are plugged in. Without drilling, without releasing terminal strips, without complicated installation.

A magnet holds the Plug & Light light attachment onto the light socket, which supplies the luminaire both with the energy necessary for operation and with the data for the smart functions: the light attachments can be independently and continuously dimmed.

# The smart home systems from JUNG



From the intelligent socket right up to a completely networked smart home in accordance with the DIN standard: our solutions combine ease of operation and the special JUNG design. Which of the three systems is the right one for you depends on your building plans and your own requirements.

**JUNG HOME smartifies both new buildings and existing ones.**

The system uses the conventional 230 volt installation. Commissioning and operation are achieved very easily using Bluetooth® Mesh and the JUNG HOME app – starting from just one socket.



**The flexible, wireless smart-home system: JUNG eNet SMART HOME is installed quickly and cleanly – even when retrofitting.**

The great advantage of the wireless technology is, among others, that no cables have to be laid during installation and thus the walls remain undamaged. In addition, it can be extended at any time. Comprehensive scene control is achieved by using a server.



**KNX networks, controls and visualises all components connected to the control cable decentrally in the building.**

As a proven, worldwide standard, KNX is future-proof and offers alongside automation many possibilities for sustainable and efficient living. KNX is particularly suited to new buildings.





# JUNG HOME. JUST SMART.



TRANSMISSION PATH:  
BLUETOOTH® MESH

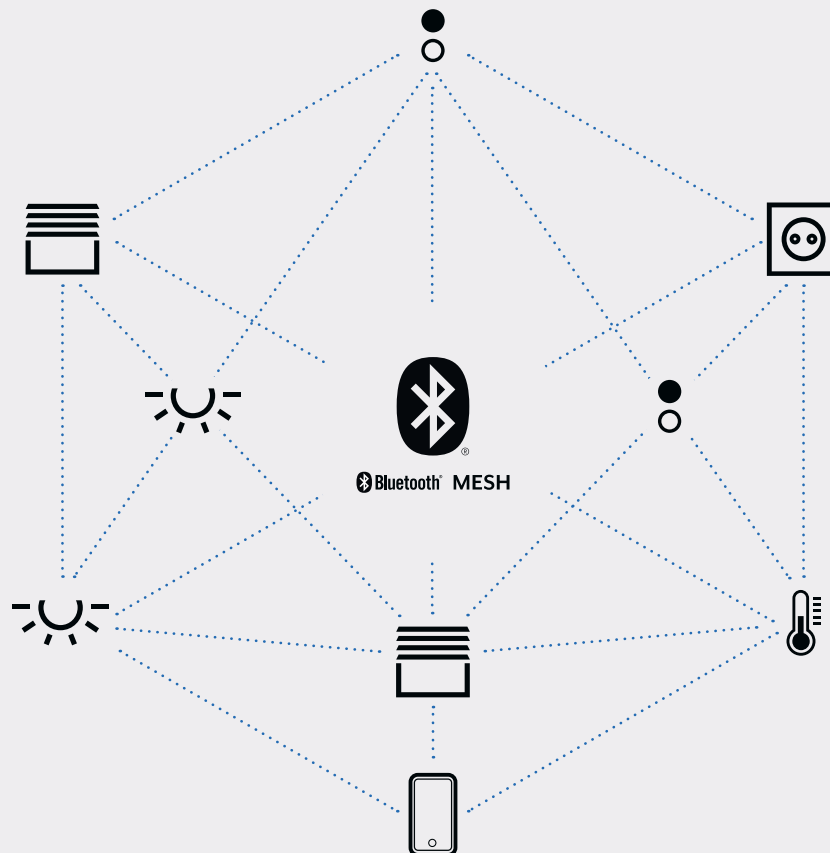

You don't have to be an expert to make your home smart. All that is needed is the right technology. Light, shade, temperature: at its core, JUNG HOME consists of system inserts, covers and sockets. Locally networked using Bluetooth® Mesh. Commissioning and operation are carried out with the JUNG HOME app.

# Operating JUNG HOME

**1-GANG PUSH-BUTTON**



**2-GANG PUSH-BUTTONS,  
BATTERY-POWERED**

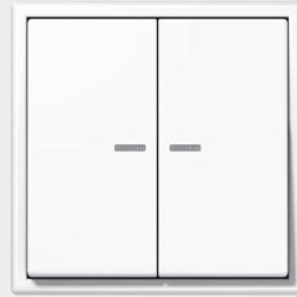

**MOTION DETECTOR 1.1 M**



**ROOM THERMOSTAT DISPLAY**



In the JUNG HOME, you control the functions with smart push-buttons. The push-buttons are also available as battery-operated versions and can be placed independently of the 230-volt-installation. JUNG HOME is energy-efficient, thanks to the motion and presence detectors. The motion detectors detect in a

range of 180 degrees, the presence detectors register movements in 360 degrees. And you can regulate the temperature as well in accordance with your requirements: energy efficient and simply smart. Everything networked using Bluetooth® Mesh and configured simply with the JUNG HOME app.



Richard Yates  
Verdammte Tage  
LFA

Muschelstrand  
Meyer Hermannson  
SV

Richard Bachman  
Der Polkatz  
P&K

Laila Lalami  
Die Araber  
P&K



# Smart SCHUKO<sup>®</sup> sockets

## JUNG HOME SCHUKO<sup>®</sup> SOCKET ENERGY



SAFETY<sup>+</sup>

## STATUS LED



The LED on the socket is an on-off switch at the same time. It additionally displays the status of the socket.

## JUNG HOME APP

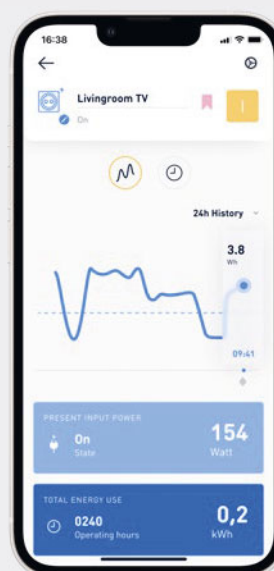

Precise charting per hour or day: the JUNG HOME app displays the exact energy consumption.

With the JUNG HOME SCHUKO<sup>®</sup> sockets, you reduce your electricity consumption and gain in convenience and safety at the same time. The Energy version measures electricity consumption and thus allows targeted energy management. The smart sockets are switchable using JUNG HOME push-buttons, the

JUNG HOME app or using the LED push-buttons on the socket itself. The sockets have 16 time programs with astro function and automatic summer and winter time adjustment. Furthermore, they have a random function, a run-on time and a switch-on and switch-off delay.

# The JUNG HOME gateway



The JUNG HOME gateway connects the system with the Internet or other gateways. That enables you to have remote access via apps and voice control of all connected devices.

JUNG HOME devices with the myJUNG Cloud using Bluetooth® Mesh. You already have voice control using Amazon Alexa or Google Assistant. Simply connect it to your router. The wire-

less communication is also encrypted via the gateway. The gateway has the Mesh repeater function.

# Hello IoT world



The integration of JUNG HOME into systems such as SmartThings, wibutler and WORKS WITH mediola® opens up even more networking possibilities for you.

SmartThings involves an app from Samsung that enables smart home elements to be controlled by smartphone, smart watch or voice. This includes intelligent lamps, thermostats and sockets. Products and solutions from VELUX, Schüco, Vaillant, Sonos, Philips

Hue and many other providers can be networked with the service from mediola®. Wibutler is an IoT platform for digital building technology. It networks and controls over 300 products from more than 45 manufacturers.



# eNet SMART HOME

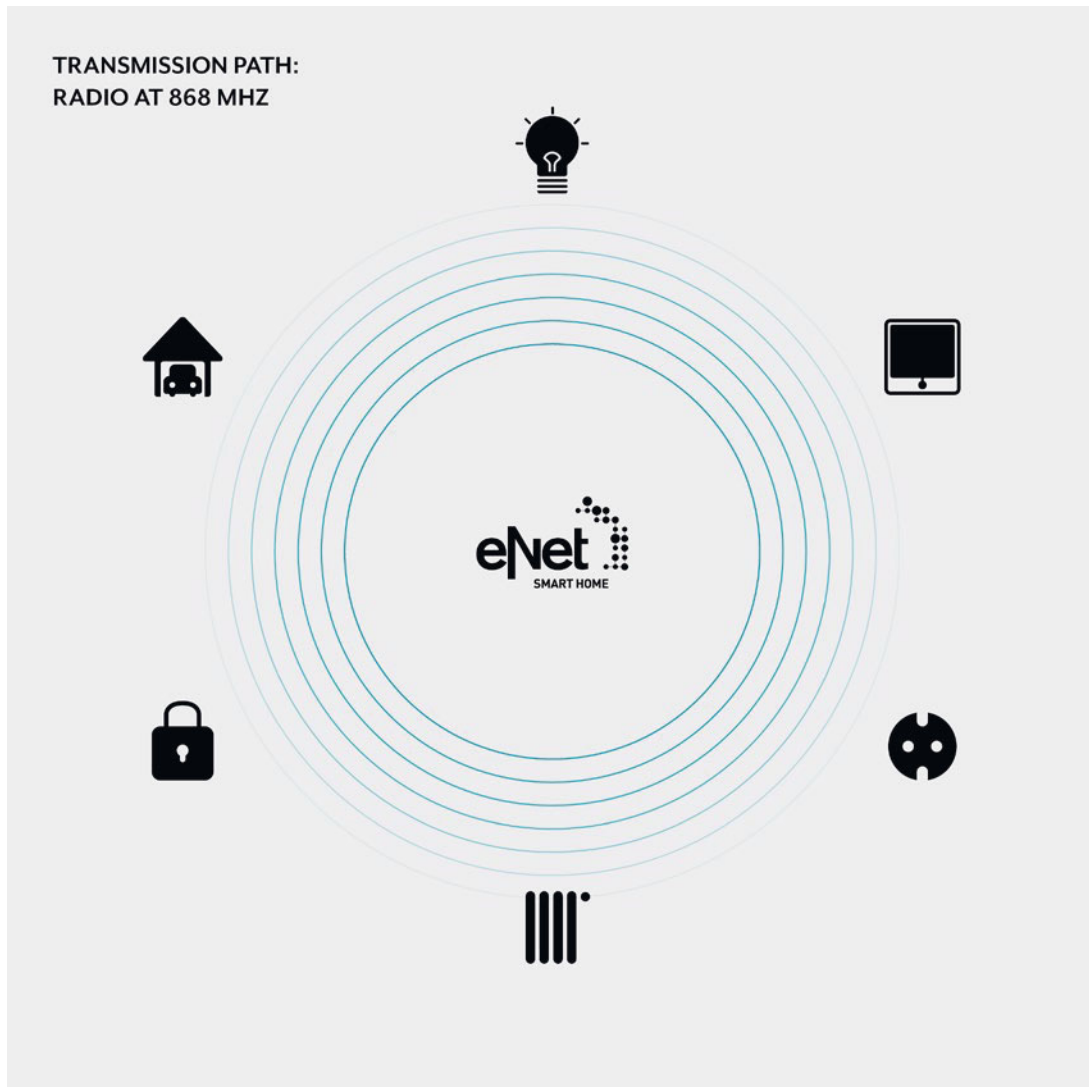

Light, blinds, heating and many other functions can be conveniently controlled with eNet SMART HOME – from home or also on the move with remote access. As the manufacturer-independent system requires no cables, it can be installed quickly without having to lay cables or similar. The eNet server enables comprehensive scene control.



# Control individually

Via smartphone and tablet or via a stationary touch display – with the JUNG eNet SMART HOME App, users have access to the entire building technology at all times. The various functions can be controlled easily and intuitively via a fully encrypted, VDE-certified connection. It does not matter whether you operate JUNG eNet SMART HOME at home on your own WLAN or via remote access on the move.



## INTELLIGENT VOICE CONTROL

JUNG eNet SMART HOME is compatible with the Amazon Alexa and Google Assistant voice services.

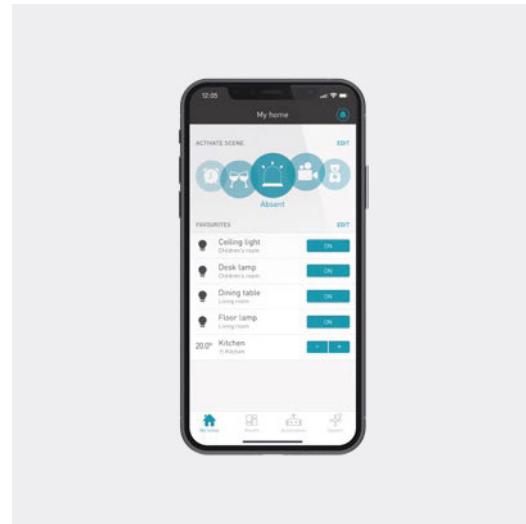

## eNet SMART HOME APP

At home or on the move: one finger tip is enough. The user interface of the app is adapted to iOS and Android in each case.

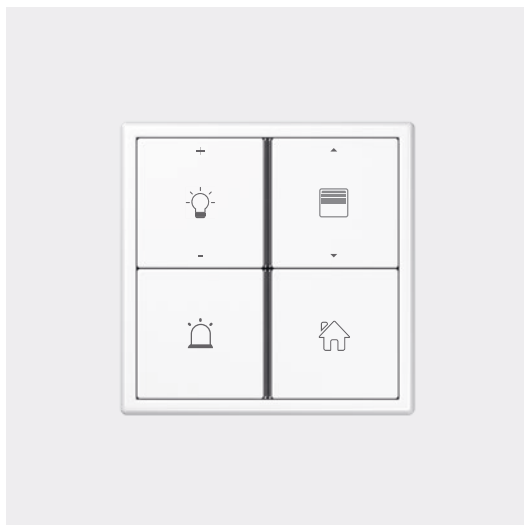

## eNet WALL TRANSMITTERS

The battery-powered wall transmitters are simply placed where they are needed, independent of the electrical installation.



## eNet RECEIVERS

The receivers are available in various designs and can be installed according to local conditions.

# JUNG eNet SMART HOME meets IoT

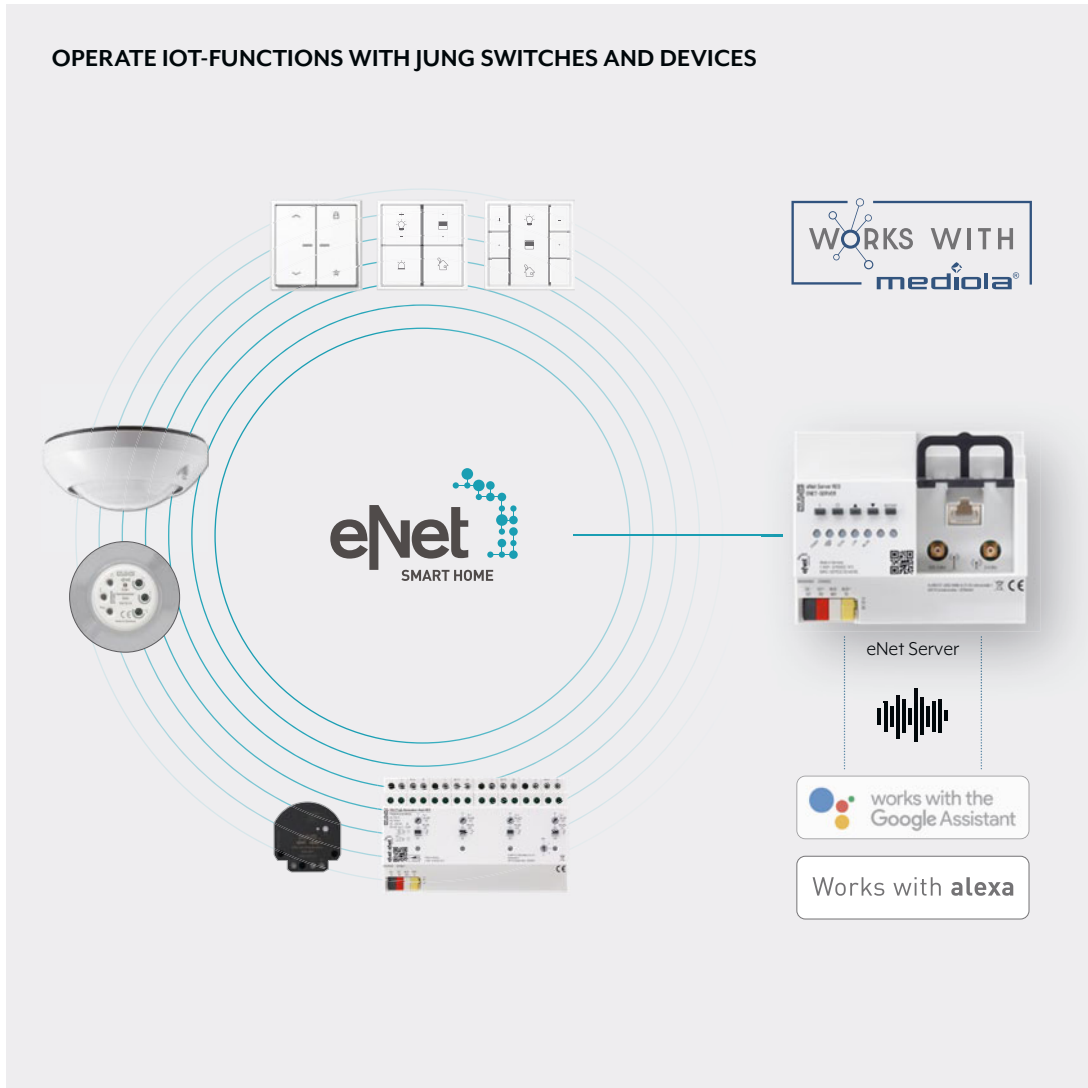

With the connection to WORKS WITH mediola®, JUNG connects the eNet SMART HOME to the Internet of Things. This opens up numerous new possibilities for you to make your daily life more convenient and more secure.

The WORKS WITH mediola® is a system of the cloud and gateways. It combines numerous solutions from the Internet of Things. Consistent and matched to the interior, with mediola® and eNet SMART HOME you control, for example, your VELUX INTEGRA® roof windows with a press on a JUNG F 40 radio transmitter or with the mediola® app. In addition, you can control the music volume of your Sonos sound system with the same eNet push-button, as it can be allocated up to eight functions. To exhaust the new possibilities, alongside an eNet Server with remote access, a WORKS WITH mediola® AIO Gateway is required.



#### **LIGHT AND MUSIC: AMBIENCE AT THE TOUCH OF A BUTTON**

It makes no difference whether it is early in the morning, watching TV or during the evening meal: with Philips Hue, eNet SMART HOME and mediola®, you can always create the right lighting atmosphere at home.



#### **MORE SAFETY IN YOUR HOME**

Users of CO and smoke alarm devices from Eltako or Netatmo provide even more security with eNet SMART HOME and mediola: in this way, in an emergency, all connected shutters open automatically, escape routes are free and the fire brigade can reach the potential seat of the fire better.

© BERND GRUBER ALL RIGHTS RESERVED



# JUNG KNX system

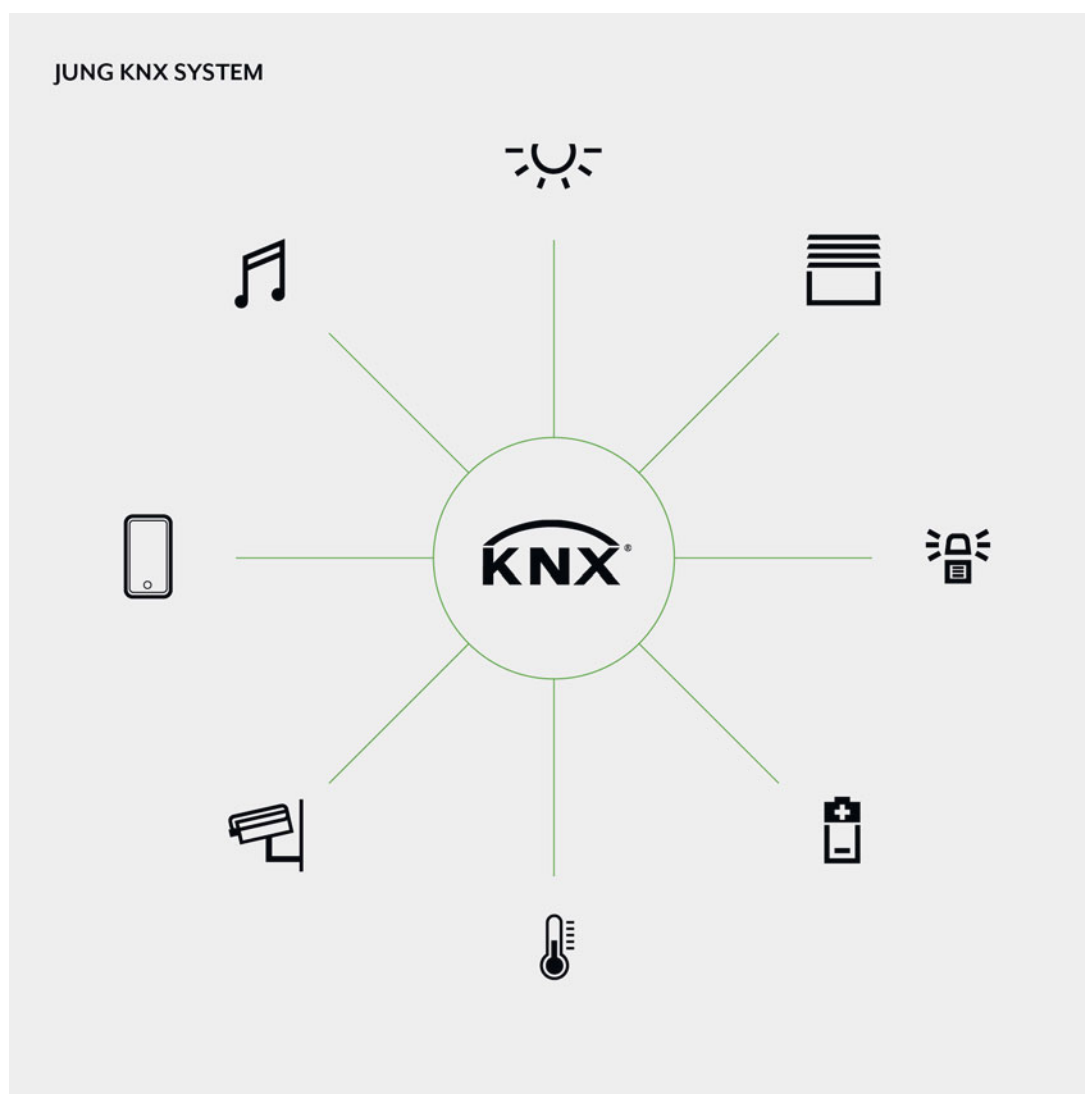

KNX is the only worldwide uniform standard for building automation technology, with currently 123,000 partners in 190 countries. More than 8,000 devices from over 500 manufacturers communicate with each other thanks to the KNX standard. The applications and functions are continuously extended. Connection to many other systems, protocols and standards is also possible with KNX.

# Smart home central unit

## JUNG SMART VISU SERVER



Perfect light at all times, living spaces heated as required, significantly more security – a Smart Home makes your life easier. The compact JUNG Smart Visu Server provides even more comfort. It visualises and controls all processes in the KNX system. Lighting, temperature, sun protection, music and more: Residents control all functions via the Smart Visu Server App using a smartphone or tablet.

Smart Home components such as Alexa, Google Assistant, Philips Hue, Sonos or the IoT world of SmartThings can also be easily integrated into the system with the server. KNX functions can be implemented quickly and inexpensively thanks to Smart Visu Server. The software can be updated and upgraded.



Smart Visu Server app



# Smart building central unit

## JUNG VISU PRO SERVER

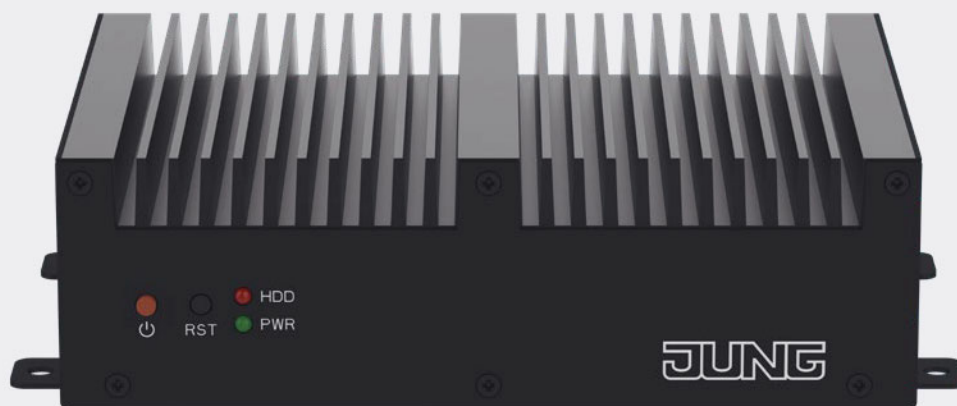

The JUNG Visu Pro Server is suitable for complex KNX applications, both in the commercial as well as the private area. The universal talent provides a wide range of customisation options and maximum security.



The JUNG Visu Pro Server is the professional way to visualise and control building automation. Multiple, independent KNX systems can be operated and configured conveniently at the same time. In combination with Amazon Alexa or the Google Home Assistant, the Visu

Pro Server enables voice control of the building technology. Thanks to remote access, users can conveniently access the system while on the move. For extra security, the communication is encrypted with KNX Secure.

# Intelligent voice control

The connection of KNX building technology with the Internet of Things makes the home even more convenient. Important interface: the JUNG voice control.

## KNX MEETS VOICE CONTROL

Your Smart Home listens to the word, thanks to the JUNG voice control. It is the crucial interface between future-proof KNX technology and the Internet of Things: The JUNG voice control must be activated in the Smart Visu Server or Visu Pro Server so that the subsystems behind the KNX technology become speech-compatible. The connection to the voice control is very simple and can be realised quickly by the specialist for his customer. In consultation with the customer, the system integrator selects the building functions that should be controlled.



## MANAGING VOICE COMMANDS

Users can customise voice commands for maximum convenience. Also subsequently. For example, an imprecise “switch on wall lamp” becomes a more specific “switch on the ceiling floodlight in the living room”. However, devices outside the KNX universe can also be integrated into the voice control system by the user. This is then linked to the KNX functions accordingly – thanks to the JUNG voice control interface.

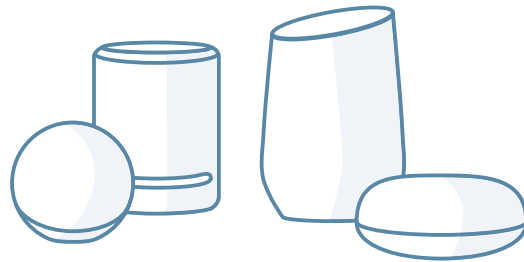

Amazon Echo Studio  
Amazon Echo Dot

Google Nest Audio  
Google Nest Mini





# Central operation using touch displays

## SMART PANEL 5

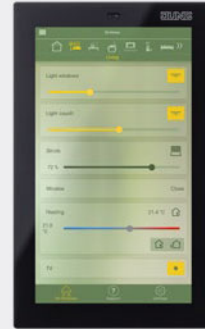
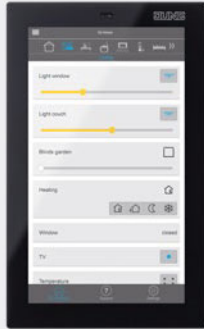

127 mm / 5"

## SMART CONTROL 8

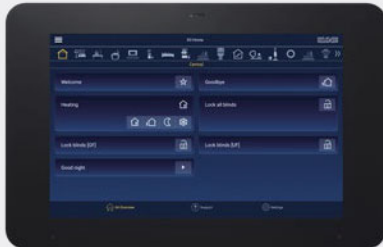

203 mm / 8"

Multifunctional touch displays for intelligent buildings: the Smart Control 5 and 8 take over the control and visualization of the KNX system. Thanks to the JUNG Launcher, all available applications are clearly displayed and can be called up directly by tapping on the respective icon. In this way, operation of the building technology becomes simple and convenient.

The high-resolution graphic display of the Smart Control 5 is reminiscent of the newest smartphones in respect of its appearance, brightness of the colours and sharpness. The new JUNG Smart Control 8 is a capacitive touch display for operating all functions from door communications to controlling the smart home. The 8-inch display (20.32 cm) has an HD screen.



# Central operation without a server

## SMART PANEL 8



Thanks to the large symbols and font, the display is clear and easily understood.

## SMART VISION APP

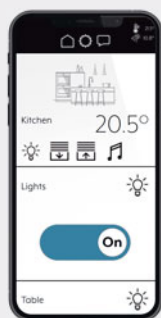

With the Smart Vision app for smartphones and tablets, you can also control the Smart Panel 8.

The Smart Panel 8 is a touch screen for direct KNX visualisation without an additional server: centrally on the wall and with an app for a smartphone or tablet. The JUNG Smart Panel 8 offers comprehensive possibilities for intuitive control of your KNX system. The app interface

is called JUNG Smart Vision and can be operated intuitively. Various rooms such as living room, bedroom, kitchen, etc. are set up in the main menu and provided with functions entirely as you wish. The Smart Panel 8 can be planned in at the time or added later.

# KNX room controller LS TOUCH

## LS TOUCH IN THE LS 990 RANGE



in stainless steel



in white

## LS TOUCH IN THE LS ZERO RANGE



in Les Couleurs® Le Corbusier rouge vermillon 59



in Les Couleurs® Le Corbusier gris moyen

With the KNX room controller LS TOUCH, up to 32 smart home functions can be controlled within a room – from the lighting via the heating to the multimedia. The smart touch display in switch format combines simple, intuitive operation of functions with visualisation of the system. LS TOUCH is based on clear and easily understood symbols and the

operating philosophy is reminiscent of the operation of modern smartphones: the functions are called by swiping on the display. LS TOUCH is permanently connected with a 1-gang frame from the JUNG LS 990 or LS ZERO switch ranges and is available in a variety of materials and colours.



# KNX push-button F 10



## KNX PUSH-BUTTON F 10 STANDARD



in LS 990 in aluminium

## KNX PUSH-BUTTON F 10 STANDARD



in A 550 in white

## KNX PUSH-BUTTON F 10 UNIVERSAL



in CD 500 in white

## KNX PUSH-BUTTON F 10 UNIVERSAL

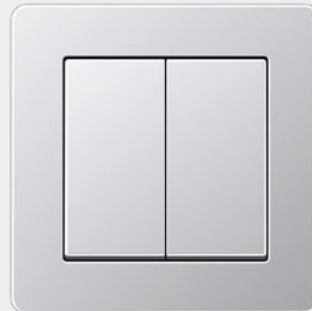

in A FLOW in aluminium look

Smart functions, stylish design: The JUNG KNX push-button F 10 looks like a classic light switch, but masters intelligent KNX technology. Operation is particularly simple: The individual switching points can be assigned multiple times and are completely customisable. Available with covers and devices from the A, AS, CD and LS ranges, the KNX push-button F 10 integrates perfectly into any interior.



### KNX SECURE

Effective protection with AES128 encryption and double protection: KNX IP Secure encrypts the transmission at network layer. KNX Data Secure encrypts and authenticates the data on the KNX bus line.



KNX push-button F10 universal in the range LS 990 in matt snow white



KNX push-button F 40 in the range LS 990 in matt graphite black

# KNX push-button F 40



## KNX PUSH-BUTTON



in LS 990 in dark

## KNX PUSH-BUTTON RF



in LS 990  
Les Couleurs® Le Corbusier 32030 bleu céruléen

## KNX COMPACT ROOM CONTROLLER



in LS 990 in stainless steel

## KNX PUSH-BUTTON



in LS 990 in stainless steel

The KNX push-button and room controllers of the F 40 family are designed for convenient operation via their large buttons. These are used to control both the classic room functions such as lighting, shutters and temperature as well as entire feel-good scenes or multimedia components.

These can be individually marked according to your wishes and intended use using the JUNG Graphic Tool for better function allocation. Centrally arranged, coloured LEDs for operation and status display round off the easy handling.

# KNX Taster F 50



## KNX PUSH-BUTTON



in LS 990 in classic brass

## KNX PUSH-BUTTON RF



in LS 990  
Les Couleurs® Le Corbusier 4320L ocre jaune clair

## KNX COMPACT ROOM CONTROLLER



in LS 990 in aluminium

## KNX ROOM TEMPERATURE CONTROLLER

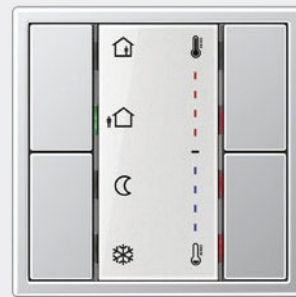

in LS 990 in aluminium

The KNX push-button F 50 in the design of the AS, A, CD and LS ranges are impressive with their homogeneous surface appearance and harmonious overall appearance. The components are uniformly designed with

operating buttons on the left and right and a large display or cover in the middle. The cover is available either as a transparent labelling area or matching the button colour.



KNX push-button F 50 in the range LS 990 in matt snow white

# Conventional gets smart

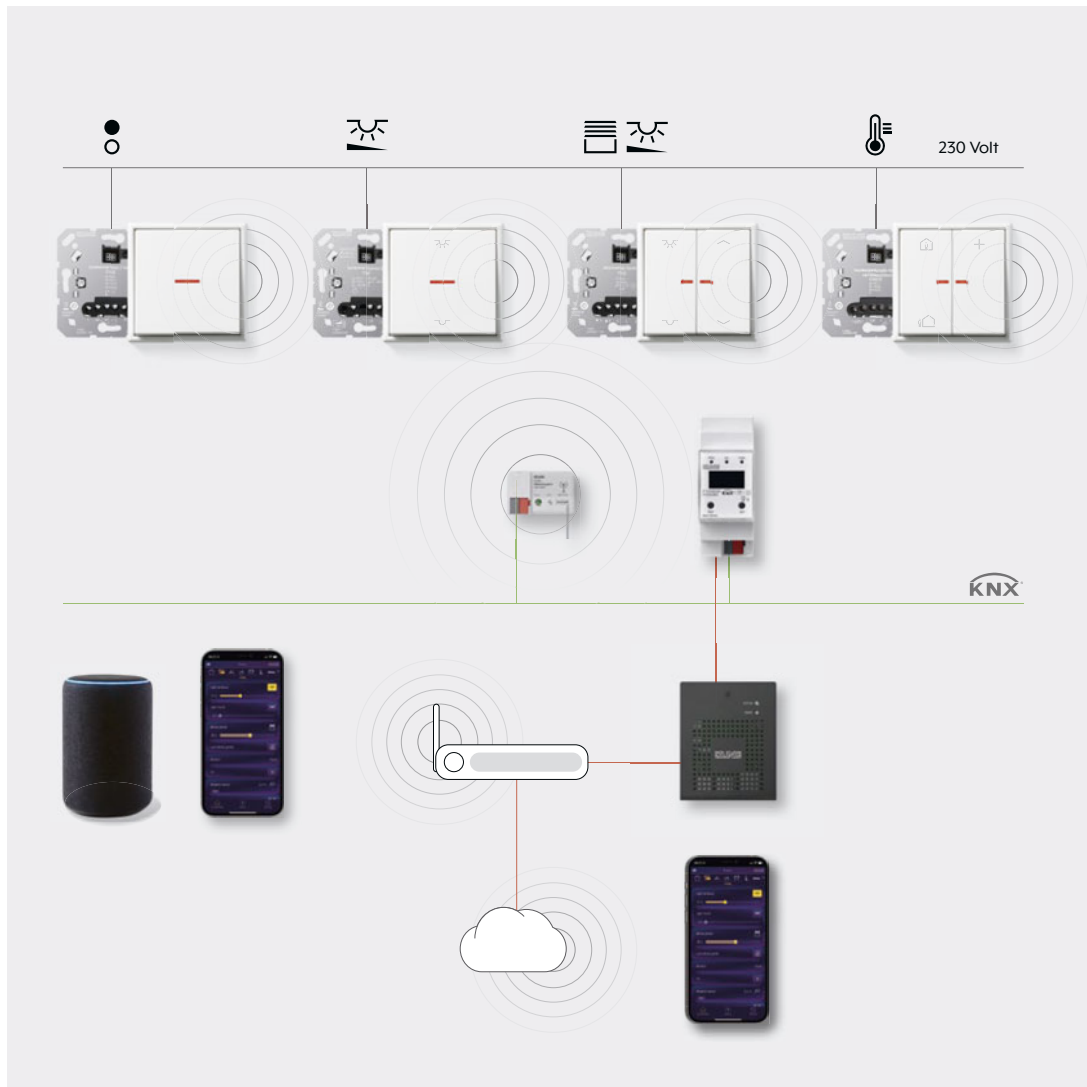

Smart living with the KNX RF radio standard (RF = radio frequency) in the JUNG design: KNX RF devices bridge structural conditions where no bus lines can or should be installed. In this way, the JUNG KNX RF push-buttons make the classic 230 volt installation smart – wireless and without additional cables needing to be

laid. At the position where a conventional light switch used to be, a smart home control unit can be found. Connected with a JUNG Server, users get a fully functional smart home including voice control, visualisation and operation with a smartphone or tablet.



KNX RF push-button in the LS 990 range in matt snow white

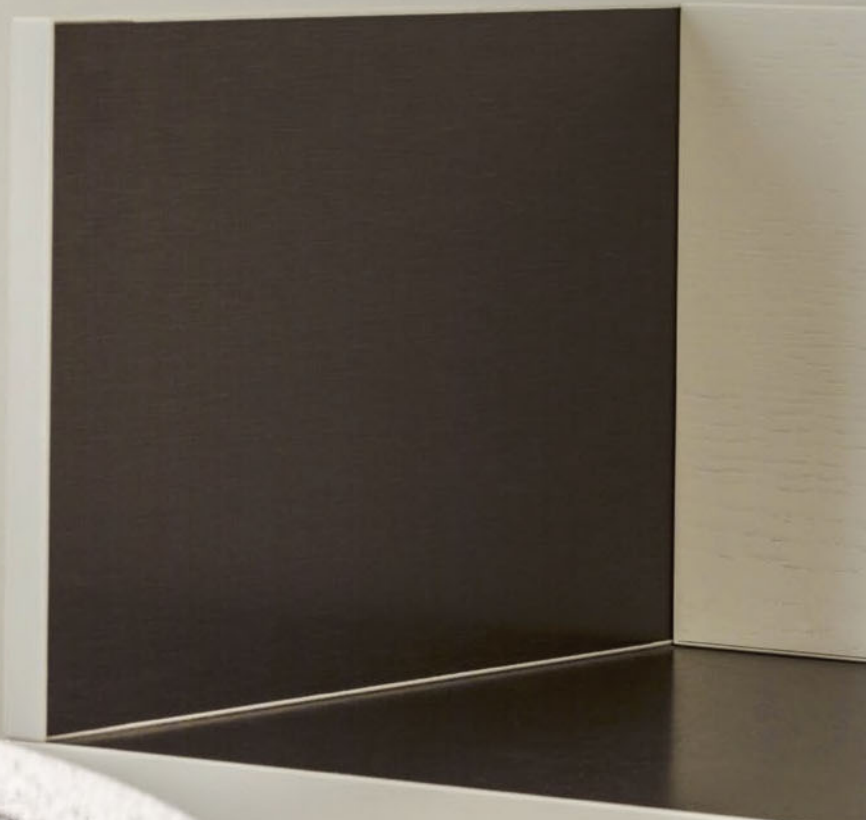

Triple combination of a hotel installation in the range LS 990 in dark

# The GRAPHIC TOOL

## LASER ENGRAVING



The laser engraving process enables contours of symbols, texts and ornaments due to the precise removal of the surface.

## COLOUR PRINTING



The abrasion-resistant colour printing provides numerous possibilities for individual design.

## LABELLING



Integrated inscription fields can be designated via labelling process. This optimises the assignment of functions.

With the GRAPHIC TOOL, you can design switches, sockets, KNX push-buttons, room controllers and many other devices completely individually. You can customise all of these operating elements online with symbols, text or logos.

The JUNG GRAPHIC TOOL supports laser engraving, colour printing and identification of inscription fields. The procedure used depends on your personal demands and the individual product and material.

LS 990

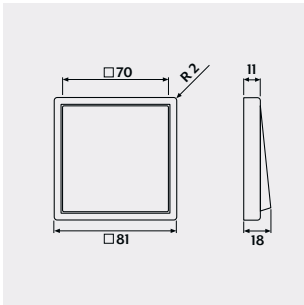

**Plastic**

- ivory
- white
- matt snow white
- light grey
- black
- matt graphite black

The LS 990 also comes in the 63 Les Couleurs® Le Corbusier colours (page 110).

**SILVERPLUS®**

- white

The special JUNG SILVERPLUS® material technology has an antimicrobial effect and reduces the number of germs on surfaces. The broad spectrum effect of SILVERPLUS® includes fungi and enveloped viruses such as SARS\_CoV-2 virus in addition to bacteria.

LS 990

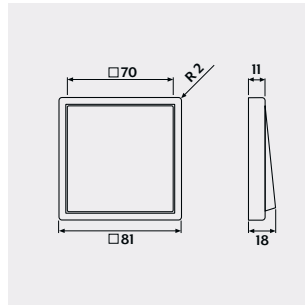

**Metal**

- aluminium
- stainless steel
- anthracite\*
- dark\*
- chrome
- golden
- gold-plated
- classic brass
- antique brass

LS ZERO

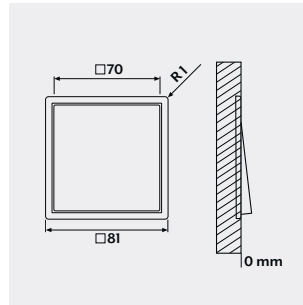

**Plastic (frames)**

- aluminium
- stainless steel
- dark
- classic brass
- white
- matt snow white
- matt graphite black

LS ZERO also comes in the 63 Les Couleurs® Le Corbusier colours (page 110).

The covers can be selected from the colour and material spectrum of the LS range.

LS CUBE

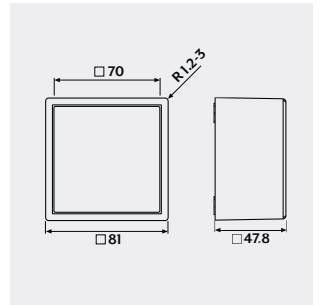

**Plastic (frames)**

- aluminium
- stainless steel
- ivory
- white
- matt snow white
- light grey
- black
- matt graphite black

LS CUBE also comes in the 63 Les Couleurs® Le Corbusier colours (page 110).

The covers can be selected from the colour and material spectrum of the LS range.

\* (lacquered aluminium)

LS 1912

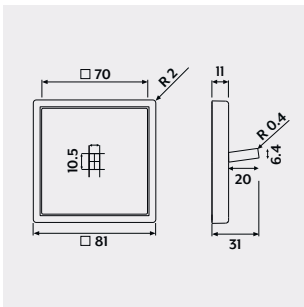
**Metal**

aluminium	
stainless steel	
dark*	
classic brass	
chrome	
matt snow white*	
matt graphite black*	

LS 1912 also comes in the 63 Les Couleurs® Le Corbusier colours (page 110).

The shape and material of the toggle switches in LS 1912 are matched to each other. Cylinder and cone are available in aluminium, stainless steel, classic or dark brass. The cube version is available in chrome.

LS PLUS

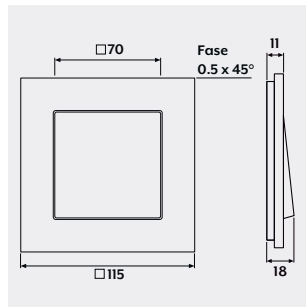
**Glass (frames)**

mattweiß	
white	
black	

The covers can be selected from the colour and material spectrum of the LS range.

LS DESIGN

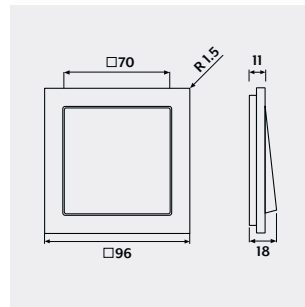
**Metal**

aluminium	
stainless steel	
anthracite*	
dark*	
chrome	
classic brass	
antique brass	

**Plastic**

ivory	
white	
light grey	
black	

\* (lacquered aluminium)

A 550

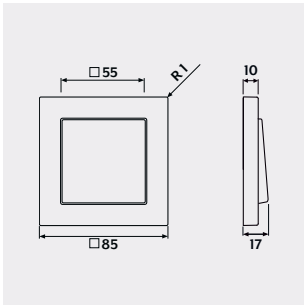

**Plastic**

white	
matt snow white	
black	
matt graphite black	
aluminium	
champagne	
mocha	
matt anthracite	

A FLOW

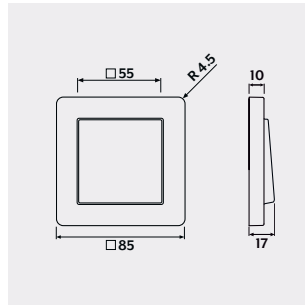

**Plastic**

white	
matt snow white	
black	
matt graphite black	
aluminium	
champagne	
mocha	
matt anthracite	

A VIVA

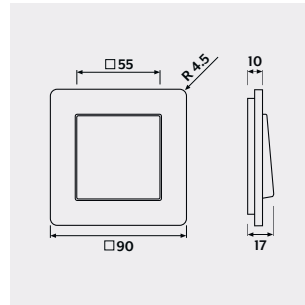

**Glass (frames)**

white	
black	
champagne	
mocha	
emerald green	
night blue	
crystal grey	

The covers can be selected from the colour spectrum of the A range.

A CREATION

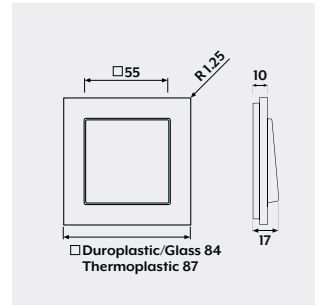

**Plastic (frames)**

white	
black	
aluminium	
champagne	
mocha	
matt anthracite	

**Glass (frames)**

white	
black	
champagne	
mocha	
emerald green	
night blue	
crystal grey	

The covers can be selected from the colour spectrum of the A range.

A CUBE

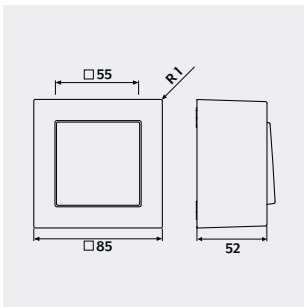

**Plastic**

- white
- matt snow white
- black
- matt graphite black
- aluminium
- matt anthracite

AS 500

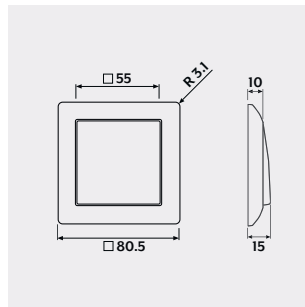

**Plastic**

- ivory
  - white
- SILVERPLUS®**
- white

The special JUNG SILVERPLUS® material technology has an antimicrobial effect and reduces the number of germs on surfaces. The broad spectrum effect of SILVERPLUS® includes fungi and enveloped viruses such as SARS\_CoV-2 virus in addition to bacteria.

CD PLUS

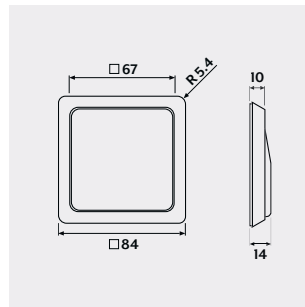

**Plastic (frames)**

- white
- light grey
- black

**Colour application**

- light grey
- yellow
- light green
- stainless steel
- granite
- metallic green
- metallic black
- metallic blue
- metallic red
- chrome
- gold

The covers can be selected from the colour and material spectrum of the CD range.

CD 500

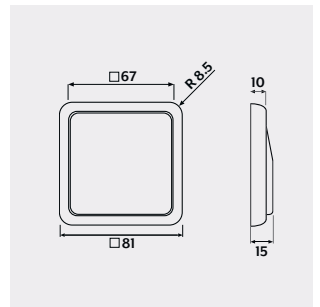

**Plastic**

- ivory
- white
- brown
- grey
- light grey
- black

**Metal**

- platinum\*
- gold-bronze\*

\* (lacquered aluminium)

# LS 990 in Les Couleurs<sup>®</sup> Le Corbusier

The colour palette of 1931

Basic colour



**32001**  
blanc  
HBW 72



**32010**  
gris foncé 31  
HBW 12



**32020**  
bleu outremer 31  
HBW 16



**32030**  
bleu céruléen 31  
HBW 14



**32040**  
vert anglais  
HBW 13



**32050**  
vert foncé  
HBW 12

Brightening

The 1931 colour palette includes 43 colours in 14 series. Each series consists of one solid colour and up to four graduated brightenings.



**32011**  
gris 31  
HBW 29



**32021**  
outremer moyen  
HBW 40



**32031**  
céruléen vif  
HBW 30



**32041**  
vert anglais clair  
HBW 39



**32051**  
vert 31  
HBW 32



**32012**  
gris moyen  
HBW 39



**32022**  
outremer clair  
HBW 49



**32032**  
céruléen moyen  
HBW 42



**32042**  
vert anglais pâle  
HBW 57



**32052**  
vert clair  
HBW 49



**32013**  
gris clair 31  
HBW 49



**32023**  
outremer pâle  
HBW 54



**32033**  
céruléen clair  
HBW 52



**32053**  
vert jaune clair  
HBW 61



**32024**  
outremer gris  
HBW 75



**32034**  
céruléen pâle  
HBW 64

The colour keyboard of 1959



**4320A**  
rouge vermillon 59  
HBW 13



**4320B**  
blanc ivoire  
HBW 79



**4320C**  
rose vif  
HBW 45



**4320D**  
terre sienne brûlée 59  
HBW 9



**4320E**  
noir d'ivoire  
HBW 4



**4320F**  
vert olive vif  
HBW 36

In 1959, Le Corbusier expanded the Polychromie Architecturale with 20 more intense colours and an additional colour keyboard.



**4320P**  
terre sienne claire 59  
HBW 56



**4320R**  
ombre naturelle 59  
HBW 6



**4320S**  
orange vif  
HBW 20



**4320T**  
bleu outremer foncé  
HBW 5



**4320U**  
gris foncé 59  
HBW 13



**4320W**  
le jaune vif  
HBW 67



**32060**  
ocre  
HBW 66



**32080**  
orange  
HBW 27



**32090**  
rouge vermillon 31  
HBW 10



**32100**  
rouge carmin  
HBW 10



**32110**  
l'ocre rouge  
HBW 12



**32120**  
terre sienne  
brûlée 31  
HBW 8



**32130**  
terre d'ombre  
brûlée 31  
HBW 7



**32140**  
ombre  
naturelle 31  
HBW 9



**32081**  
orange clair  
HBW 36



**32091**  
rose pâle  
HBW 65



**32101**  
rouge rubia  
HBW 10



**32111**  
l'ocre rouge  
moyen  
HBW 38



**32121**  
terre sienne  
brique  
HBW 25



**32131**  
ombre brûlée  
claire  
HBW 38



**32141**  
ombre naturelle  
moyenne  
HBW 27



**32082**  
orange pâle  
HBW 64



**32102**  
rose clair  
HBW 48



**32112**  
l'ocre rouge  
clair  
HBW 55



**32122**  
terre sienne  
claire 31  
HBW 50



**32142**  
ombre naturelle  
claire  
HBW 42



**32123**  
terre sienne pâle  
HBW 62



**4320G**  
vert 59  
HBW 22



**4320H**  
gris 59  
HBW 23



**4320J**  
terre d'ombre  
brûlée 59  
HBW 5



**4320K**  
bleu outremer 59  
HBW 11



**4320L**  
ocre jaune clair  
HBW 49



**4320M**  
le rubis  
HBW 7



**4320N**  
bleu céruleen 59  
HBW 35



**4320O**  
gris clair 59  
HBW 30

JUNG provides worldwide exclusive light switches, sockets and building technology systems in the 63 colours of Les Couleurs® Le Corbusier. The colours shown here on the switches from the LS 990 range are also available in the LS ZERO, LS CUBE and LS 1912 ranges.

# Multiple sustainability

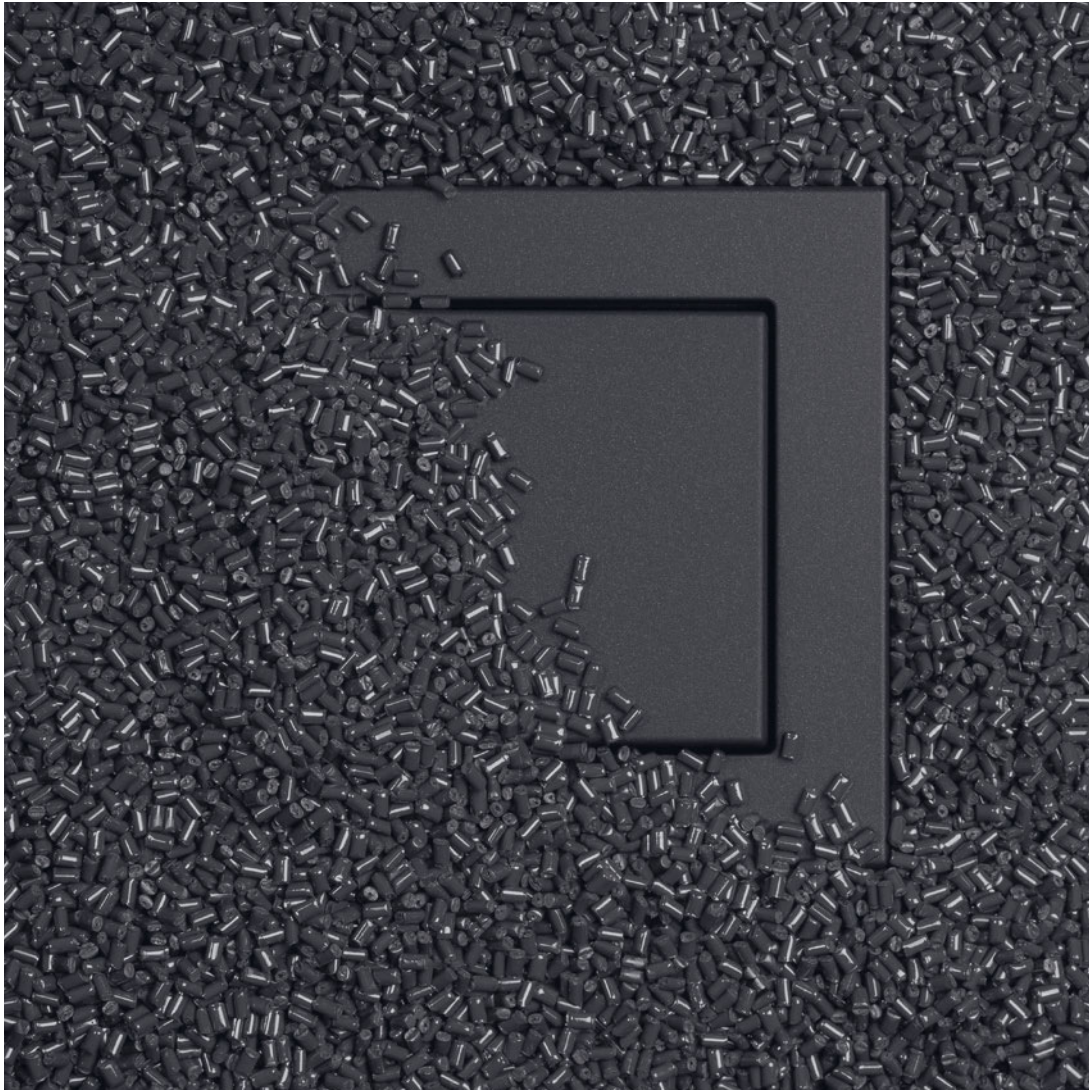

In production we have relied on recycled plastic for many years. The A CREATION, A 550, A CUBE and A FLOW switch ranges in matt anthracite already consist of 95 %

resource-saving recyclate. In this way, we contribute to reducing the environmental burden of plastic waste.



[JUNG.GROUP/RECYCLATE](https://www.jung-group.com/en/recyclate)



# Cradle to Cradle: a cycle where nothing is lost

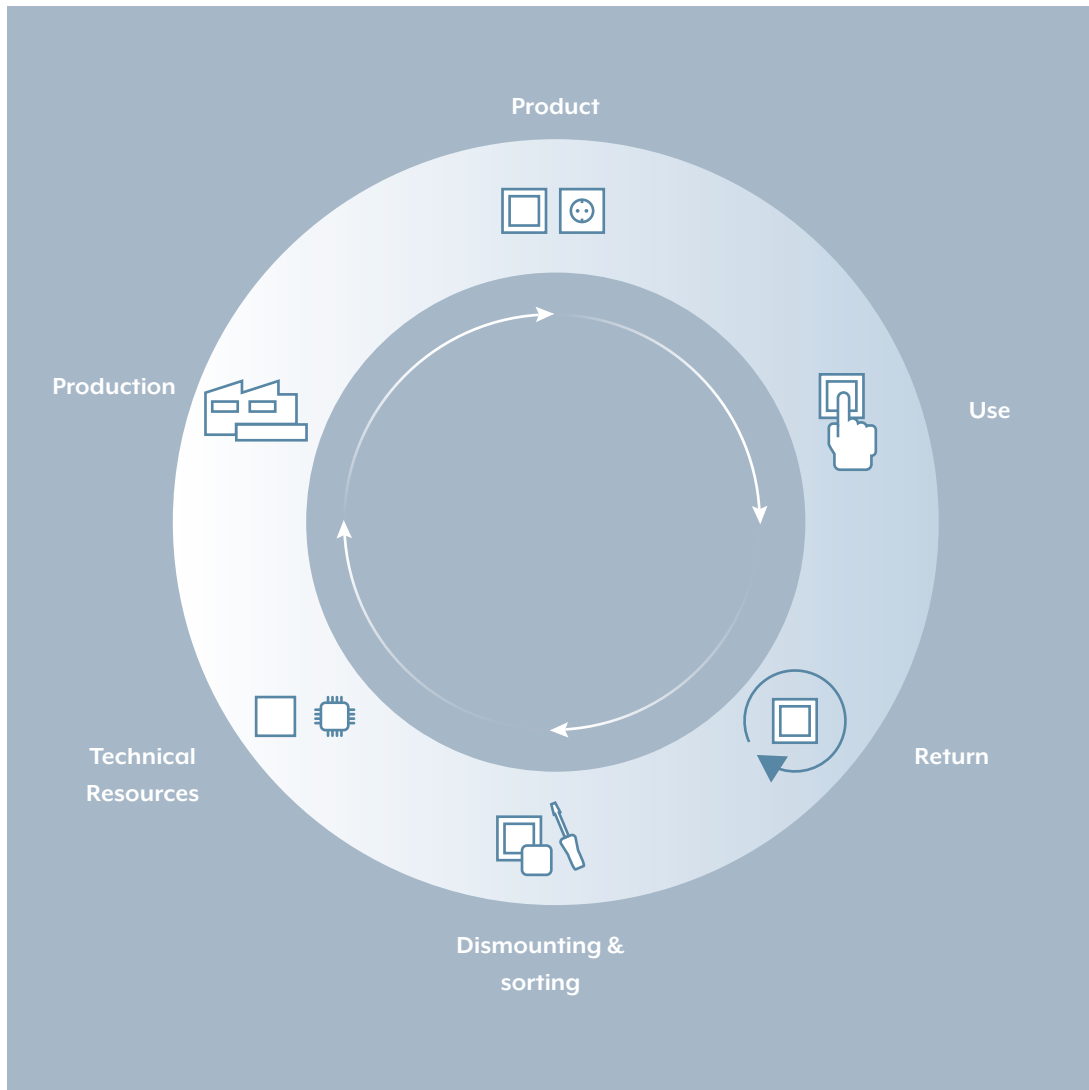

The LS 990, AS 500, A 550, A FLOW, LS CUBE and A CREATION ranges have been awarded the Cradle to Cradle (C2C) and Material

Health certificates after a rigorous testing process.



JUNG.GROUP/C2C



## Follow the inspiration

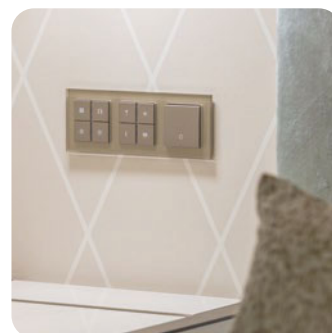
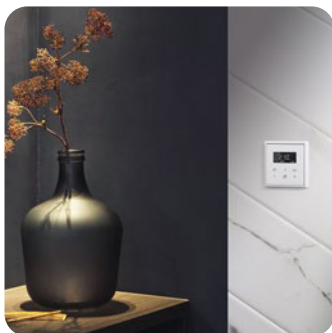

Follow JUNG on Pinterest and Instagram if you are always looking for new ideas and inspiration. On these channels you will discover inspiring designs and fascinating technology staged in high quality.



INSTAGRAM





**ALBRECHT JUNG GMBH & CO. KG**

P.O. Box 1320

58569 Schalksmühle

Germany

Phone +49 2355 806-0

Fax +49 2355 806-204

[international@jung.de](mailto:international@jung.de)

For sales contacts in your country see:  
[jung.group/contact](http://jung.group/contact)

**JUNG-GROUP.COM**